

SMALL STORAGE

ELECTRIC HOT WATER

6L Storage

2850003 - Mains Pressure Water Heater

2850006 - Open Vented Water Heater

10L Storage

2850004 - Mains Pressure Water Heater

2850007 - Open Vented Water Heater

15L Storage

2850005 - Mains Pressure Water Heater

2850008 - Open Vented Water Heater



CONTENTS

1. PREFIX	4
2. IMPORTANT NOTES & WARNINGS	4-5
3. PRODUCT OVERVIEW	6
4. INSTALLATION	7-10
5. OPERATION	11
6. USER CARE	12
7. MAINTENANCE	12
8. TROUBLESHOOTING	13-14
9. WIRING DIAGRAM	15
10. WARRANTY	15

1. PREFIX

This manual contains important information about the installation, operating and maintenance of Fala Pressure and Open (Non-pressure) Small Storage Water Heaters. Please pay close attention to the important safety information shown throughout this instruction manual. Any safety information will be accompanied by the following safety alert symbols:

 DANGER,  WARNING,  IMPORTANT

- READ THIS MANUAL CAREFULLY before installing or servicing this product.
- Improper installation, operation, or maintenance can result in death, severe injury, or property damage.
- This appliance is intended for 220-240 Volt power supply.
- **Installation MUST be carried out by a licensed and authorised technician in accordance with local electrical and plumbing codes.**

2. IMPORTANT NOTES AND WARNINGS



IMPORTANT

- Read all instructions before installing or using this appliance.
- Installation must be performed by a qualified technician in compliance with AS/NZS 3500.4, Clause G12 of the NZ Building Code, and all other current national and local regulations.
- Retain this manual for future reference.
- Use this appliance only as described in this manual. Any other use not recommended by the manufacturer may cause fire, electric shock, injury or death to persons.
- Improper installation, adjustment or alteration and failure to follow the warnings and instructions in this manual could result in severe personal injury, death or property damage.
- The manufacturer is not responsible for any damage that could happen from improper use. The manufacturer emphasises that this appliance should be used in a responsible manner and that all procedures, warnings, and safety instructions contained in this booklet be followed strictly.
- Check the appliance for damage. Do not operate a damaged unit.
- Check for damage to the appliance regularly. If damage to the appliance is suspected, discontinue use immediately and contact the supplier or qualified person to repair.
- **This appliance is not intended for use by persons (including children) with reduced physical, sensory or mental capabilities, or lack of experience and knowledge, unless they have been given supervision or instruction concerning use of the appliance by a person responsible for their safety.**
- Keep packaging material out of reach of children.
- **Children should be carefully supervised to ensure that they do not play with the appliance.**
- Do not attempt to alter the appliance in any manner.
- **Applicable for Mains Pressure Water Heater only: DANGER Failure to operate the relief valve easing gear at least once every six months may result in the water heater exploding. Continuous leakage of water from the valve may indicate a problem with the water heater.**
- During the heat-up process, water will drip from the safety valve.
- **Open Vented Water Heater** must be installed with a vented tap. No other components are allowed to be fitted to this hot water system, this includes tempering valves, filters, aerators etc. Never subject the appliance to water pressure.
- **Water with a temperature higher than 40°C has the potential to cause serious burns, particularly in children.**



IMPORTANT

- **This appliance can heat water up to 75°C, so it must not be installed for use at sanitary fixtures primarily intended for personal hygiene; however, where the system is intended to supply water for personal hygiene, a tempering valve or thermostatic mixing valve must be installed, and the delivery temperature to personal hygiene outlets must be limited to 50°C.**
- Do not perform maintenance until the appliance has been turned off and power disconnected.
- Do not operate the appliance with panels, covers or guards removed.
- If the supply cord becomes damaged, it must be replaced by an authorised service agent or similarly qualified person in order to avoid a hazard.
- If the appliance has not been used, or will not be used for a long period of time, disconnect power supply.
- Heater installation, electrical and hydraulic/plumbing work must be performed by a qualified technician.
- An extension cord must not be used to connect the heater to power.
- Only install the appliance in a room free from the risk of freezing.
- Mount the appliance on the wall. The wall must have sufficient load bearing capacity.
- Install the appliance vertically and near the draw point. Mounting orientation must be according to the heater's model (see Section 4.1 and 4.2). Installation and use of the heater in opposite/incorrect orientation will cause permanent damage to the appliance.
- **Do not connect the heater to the electric mains until the tank is filled with water and all water connections are leak checked.**
- Do not operate the appliance when the water has been emptied from the unit or pipes.
- Equipment has a maximum pressure rating of 850kPa. A Pressure reducing valve must be installed for applications where supply pressures exceed this rating. Installation of PLVs must be in accordance with national and local regulations.



WARNING

- This appliance may deliver water at high temperature. Refer to the plumbing code of Australia(PCA), local requirements and installation instructions to determine if additional delivery temperature control is required.
- For Mains Pressure Water Heater, the installed pressure relief valve and the connected drain pipe must not be sealed or blocked.
- Never extend the tap outlet with a hose.

WARNING - THIS APPLIANCE MUST ONLY BE INSTALLED IN ACCORDANCE WITH THE ACCEPTABLE PLUMBING CONFIGURATIONS SPECIFIED IN THESE INSTRUCTIONS. FAILURE TO DO SO MAY RESULT IN CONDITIONS WHERE DELIVERY TEMPERATURE CONTROL IS INADEQUATE.

Routine inspection is recommended every **3-6 months**. If the unit remains unused for **three months or longer**, it must be purged before recommissioning.

3. PRODUCT OVERVIEW

The small storage water heater series consists of closed and open system small storage water heaters. Open system heaters are not designed to sustain water mains pressure and thus must be installed with a vented tap, and no additional fixtures. The appliance utilises a steel tank and is suitable for kitchen sinks as well as workplace kitchens/kitchenettes.

Item	6L Pressure	10L Pressure	15L Pressure
Part No.	2850003	2850004	2850005
Type	Pressure Storage	Pressure Storage	Pressure Storage
Capacity, L	6	10	15
Voltage, V	220 - 240Vac, 1-phase	220 - 240Vac, 1-phase	220 - 240Vac, 1-phase
Rated Power, W	2000	2000	2000
Rated Current, A	8.1 - 9.2	8.1 - 9.2	8.1 - 9.2
Temperature Setting, °C	75	75	75
Heating Time, mins. ($\Delta T = 30^{\circ}\text{C}$)	6.6	10.6	14.9
Maximum Permissible Pressure, kPa	850	850	850
Minimum Inlet Water Pressure, kPa	110	110	110
Maximum Water Inlet Pressure, kPa	550	550	550
Dimensions, W x H x D mm	280 x 280 x 290	360 x 350 x 300	360 x 350 x 320
Weight, kg	6.2	7.4	8.4
IP Rating	IPX4	IPX4	IPX4
Water Connections	Cold = G1/2" Male Hot = G1/2" Male	Cold = G1/2" Male Hot = G1/2" Male	Cold = G1/2" Male Hot = G1/2" Male
Tank Material	Steel	Steel	Steel
Approvals	WM 040394	WM 040394	WM 040394

Item	6L Vented	10L Vented	15L Vented
Part No.	2850006	2850007	2850008
Type	Vented Storage	Vented Storage	Vented Storage
Capacity, L	6	12	15
Voltage, V	220 - 240Vac, 1-phase	220 - 240Vac, 1-phase	220 - 240Vac, 1-phase
Rated Power, W	2000	2000	2000
Rated Current, A	8.1 - 9.2	8.1 - 9.2	8.1 - 9.2
Temperature Setting, °C	75	75	75
Heating Time, mins. ($\Delta T = 30^{\circ}\text{C}$)	6.6	10.6	14.9
Maximum Permissible Pressure, kPa	850	850	850
Minimum Inlet Water Pressure, kPa	110	110	110
Maximum Water Inlet Pressure, kPa	550	550	550
Dimensions, W x H x D mm	280 x 280 x 290	360 x 350 x 300	360 x 350 x 320
Weight, kg	6.2	7.4	8.4
IP Rating	IPX4	IPX4	IPX4
Water Connections	Cold = G1/2" Male Hot = G1/2" Male	Cold = G1/2" Male Hot = G1/2" Male	Cold = G1/2" Male Hot = G1/2" Male
Tank Material	Steel	Steel	Steel
Approvals	WM 040394	WM 040394	WM 040394

4. INSTALLATION



WARNING

- Installation must be performed by a qualified technician in compliance with AS/NZS 3500.4, Clause G12 of NZ Building Code, and all other current national and local regulations.
- The heater should always be purged before initial start-up. Purge the heater each time after the water has been emptied from the heater or pipes. See 'Purging' section (page 10).
- Open Vented Water Heater:
 - The Open Vented Water Heater appliance is designed for heating domestic hot water. The appliance can supply one draw-off point. The appliance must only be installed with an open (non-pressurised) tap.
 - Do not place the vented appliance under water pressure.
 - The vented hot water system must be installed with a vented tap. No other components are allowed to be fitted to this hot water system, this includes tempering valves, filters, aerators etc.
- Mains Pressure Water Heater:
 - The Mains Pressure Water Heater is intended for heating domestic hot water. The appliance can supply one or more draw-off points.
 - The appliance is designed for under sink installation only. It is intended to heat cold water and supply one or more draw-off outlets.
 - The unit must be installed using pressure-rated taps and must be used together with the supplied safety valve, plus a non-return valve fitted in the cold-water inlet line.
 - The supplied safety valve protects the appliance from excessive pressure. The maximum permitted opening pressure is 850 kPa.
 - If the incoming water supply pressure exceeds 550 kPa, install a pressure-reducing valve set to a maximum of 550 kPa, compliant with AS 1357.2 and installed in accordance with AS 3500.4.2.
- The enamel-lined steel cylinder includes a protective anode, which helps protect the inner tank from corrosion.
- This appliance is capable of heating water to a temperature of 75°C, and thus **CANNOT** be installed in sanitary fixtures used primarily for personal hygiene.
- Only install the appliance in a room free from the risk of freezing.
- The appliance should be mounted in a way that it can be easily accessed.
- Install the appliance vertically and near the draw point. Mounting configuration must be according to the heater's model. Installation and use of the heater in opposite configuration will cause permanent damage to the appliance.
- Do not connect the heater to the electric mains until the tank is filled with water and all water connections are tight and full.
- Water with a temperature higher than 40°C has the potential to cause serious burns, particularly for children.
- The unit is equipped with a thermal cut-out set at 90°C. If the cut-out is activated, the unit will stop heating water. In this event, contact the service centre for assistance.

Pressure small storage – parts list

- 1x pressure storage tank heater unit
- 1x temperature pressure relief valve
- 1x installation kit

Tools required

- Philips head screwdriver
- Adjustable spanner
- Other tools as necessary based on site conditions

Vented small storage – parts list

- 1x vented storage tank heater unit
- 1x installation kit

4.1 VENTED TAP INSTALLATION

WARNING

- The vented heater must only be installed with the vented tap and fittings. The tap provides constant ventilation to atmosphere and prevents pressurisation of the heating chamber.

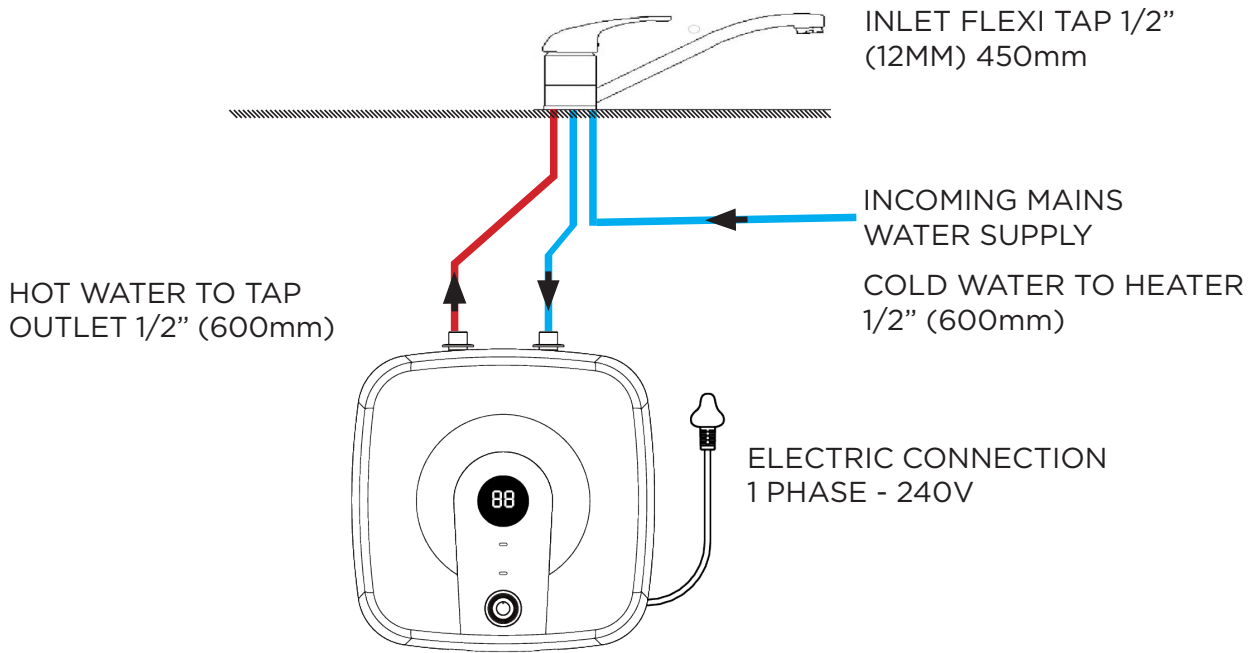

4.2. PRESSURE UNIT INSTALLATION

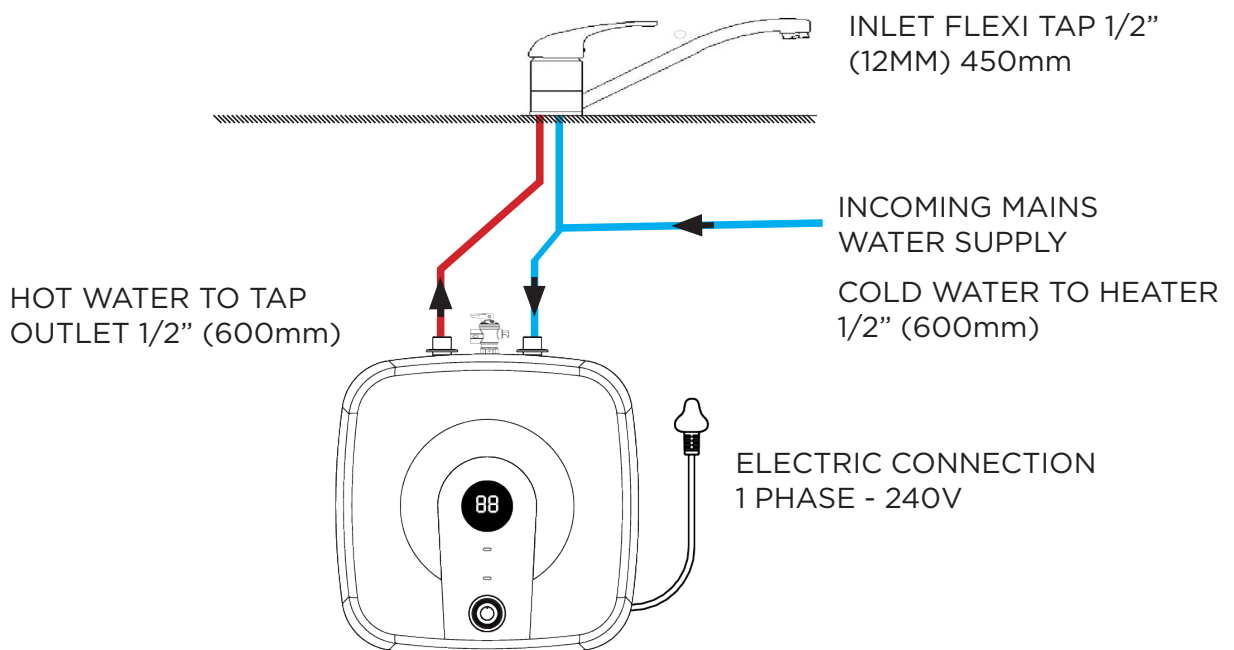

4.3 MOUNTING AND WATER CONNECTION - VENTED UNIT

IMPORTANT

- All pressure and vented units are only suitable for undersink installation.
- The water connections of the appliance must point upwards.
- Do not block/restrict the hot water outlet on the vented unit. This serves as ventilation.

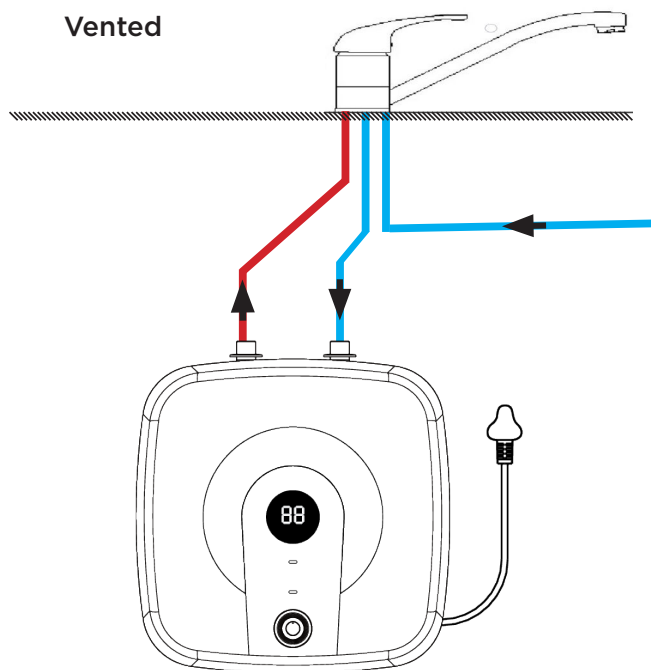

- I. Install the special hanger provided to the wall and hang the heater.
 - a. Mark the drilling points using the mounting bracket.
 - b. Drill the holes and fit suitable wall plugs.
 - c. Fix the mounting bracket to the wall using appropriate screws.
 - d. Hang the appliance on the mounting bracket.
- II. Vented unit: Connect the water connections of the vented tap to the heater and water supply.
 - a. Blue (LHS), Cold water inlet → Cold water from vented tap
 - b. Red (RHS), Hot water outlet → Hot water to vented tap
 - c. Water supply → Cold water to vented tap
- III. Check connections for leaks - THE VENTED UNIT CANNOT BE PRESSURE TESTED FOR LEAKS
- IV. Wait until the tank is completely filled before connecting the power supply and switching the unit on. Read chapter 5.1 Purging for more detail.
- V. After installation, inspect all connections to confirm they are secure and free from leaks.

4.4 MOUNTING AND WATER CONNECTION - PRESSURE UNIT

IMPORTANT

- All pressure and vented units are only suitable for undersink installation
- The water connections of the appliance must point upwards.

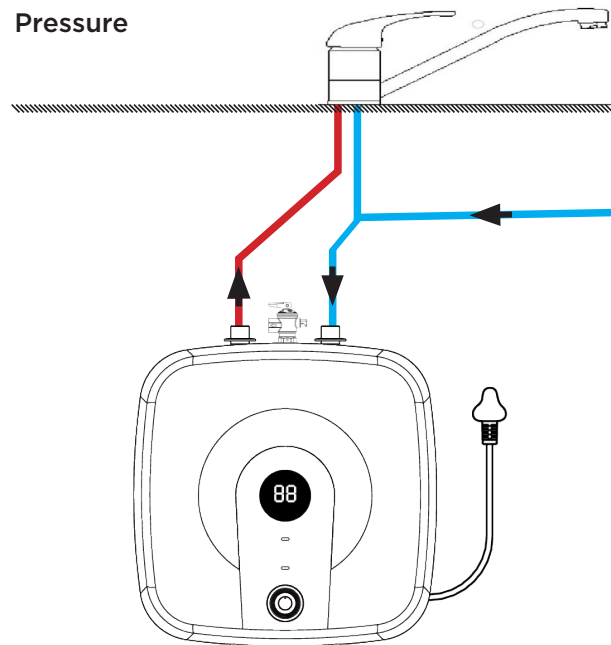

- I. Install the special hanger provided to the wall and hang the heater.
 - a. Mark the drilling points using the mounting bracket.
 - b. Drill the holes and fit suitable wall plugs.
 - c. Fix the mounting bracket to the wall using appropriate screws.
 - d. Hang the appliance on the mounting bracket.
- II. Pressure unit: Connect the water connections of the tap to the heater and water supply.
 - a. Water supply → Blue (LHS), Cold water inlet.
 - b. Red (RHS), Hot water outlet → Hot water to tap.
 - c. Water supply → Cold water to tap.
- III. Wait until the tank is completely filled before connecting the power supply and switching the unit on. Read chapter 5.1 Purging for more detail.
- IV. Mains Pressure Water Heater
 - Operate the safety valve regularly to help prevent it from sticking or becoming blocked (e.g., due to limescale build-up).
 - Size the drain line so water can discharge freely when the safety valve opens fully
 - Install the safety-valve drain line with a continuous downward fall, and route it through an area protected from freezing.
 - The safety-valve drain outlet must remain open to atmosphere (i.e., it must not be sealed or connected to a closed system).
- V. After installation, inspect the safety valve and all connections to confirm they are secure and free from leaks.

4.5 ELECTRICAL CONNECTION

IMPORTANT!

- Do not connect the heater to the electric mains until the tank is filled with water and all water connections are tight and the appliance is full of water.
- Do not use extension cords to connect the heater with a socket.
- If the supply cord becomes damaged, turn off power, unplug the unit and discontinue use.
- Electric installation MUST be equipped with residual current protective devices and other devices that ensure disconnection of power (all poles are disconnected by at least 3mm separation)
 - I. Connect the plug to a standard 10A socket.

5. OPERATION

IMPORTANT!

- **In case of a water supply failure (lack of water in system), the tap must be shut off, the unit unplugged from the power point immediately and safely isolated from the power source. The heater should be vented again after water supply is back to normal.**
- **WARNING - FOR CONTINUED SAFETY OF THIS APPLIANCE IT MUST BE INSTALLED, OPERATED AND MAINTAINED IN ACCORDANCE WITH THE MANUFACTURER'S INSTRUCTIONS.**
- **The heater should always be vented before initial start-up. Vent the heater each time after the water has been emptied from the heater or pipes. See 'Venting' section 5.1.**
- **WARNING - THIS APPLIANCE MAY DELIVER WATER AT HIGH TEMPERATURE. REFER TO THE PLUMBING CODE OF AUSTRALIA (PCA), LOCAL REQUIREMENTS AND INSTALLATION INSTRUCTIONS TO DETERMINE IF ADDITIONAL DELIVERY TEMPERATURE CONTROL IS REQUIRED.**
- For Pressure units, the supplied temperature pressure relief valve is to be fitted before operation. The appliance operates under mains water pressure. As the tank heats up, the water expands. During this expansion, a small amount of water will drip from the safety valve—this is normal and necessary. **WARNING: The safety valve or drain valve outlet pipe must not be sealed or blocked.**
- Check for damage to the appliance regularly. If damage to the appliance is suspected, discontinue use and disconnect immediately and contact the supplier or qualified person to repair.
- **Water with a temperature higher than 40°C has the potential to cause serious burns, particularly in children.**
- **Due to the design of the vented appliance, water is likely to drip on occasion when the vented tap is in the closed position. This is by design and should not be prevented.**
- Do not operate the appliance when the water has been emptied from the unit or pipes.

5.1 PURGING

- I. Unplug the unit from the power outlet.
- II. Open the hot-water tap and let it run until the flow is steady and free of air (no sputtering).
- III. Close the hot-water tap.
- IV. Plug the unit back into the power outlet.

6 USER CARE

IMPORTANT!

- Check for damage to the appliance regularly. If damage to the appliance is suspected, discontinue use immediately and contact the supplier or qualified person to repair.
- Do not use any abrasive or corrosive cleaning agents.
- Check the tap regularly. Limescale deposit at outlets can be removed with descaling agents.
- Clean the outside of the appliance with a clean damp cloth.
- Dry all surfaces with a dry cloth.

7. MAINTENANCE

WARNING!

- **All maintenance must be performed by a qualified and licensed technician.**
- Disconnect the appliance from the power supply before performing any maintenance. Never unplug the appliance by pulling on the cord. Always grasp the plug firmly and pull straight out of the outlet.
- **FOR MAINS PRESSURE WATER HEATER: DANGER: Failure to operate the relief valve easing gear at least once every six months may result in the water heater exploding. Continuous leakage of water from the valve may indicate a problem with the water heater.**

7.1 DRAINING THE TANK

WARNING!

- **Hot water may escape while draining the tank.**
 - I. Turn off power and unplug the unit.
 - II. Open the hot water tap until the water is cold to touch.
 - III. Let the water run for 3mins.
 - IV. Close the hot water tap.
 - V. Disconnect the hot and cold water fittings from the appliance.

8. TROUBLESHOOTING



DANGER!

- The operation of the thermal cut-out indicates a possibly dangerous situation. Do not reset the thermal cut-out until the water heater has been serviced by a qualified person.

8.1 TROUBLESHOOTING (USERS)

VENTED UNITS:

PROBLEM	CAUSE	REMEDY
The appliance fails to heat water.	No power.	Check the unit is plugged in, power point turned to "on", and fuses in the fuse box are functional.
Hot water is provided at reduced flow rate.	Tap blocked by scale.	Descale or replace the tap.
Very noisy while heating water.		Contact Fala.
Problems persist after applying above remedies.		Contact Fala.

PRESSURE UNITS:

PROBLEM	CAUSE	REMEDY
The appliance fails to heat water.	No power.	Check the unit is plugged in, power point turned to "on", and fuses in the fuse box are functional.
Hot water is provided at reduced flow rate.	Tap / aerator blocked by scale.	Descale or replace the tap / aerator.
Safety valve continuously drips after water has been heated.	Scale or debris blocking safety valve.	Turn the appliance off. Release any internal pressure by disconnecting the unit from both the electrical power source and the water supply. Arrange for the safety valve to be inspected by a qualified service technician.
Safety valve continuously drips.	Inlet line pressure is greater than 850kPa.	Install a pressure limiting valve set at 550kPa.
Very noisy while heating water.		Contact Fala.
Problems persist after applying above remedies.		Contact Fala.

8.1 TROUBLESHOOTING (QUALIFIED CONTRACTORS)

PROBLEM	CAUSE	REMEDY
The appliance fails to heat water.	Thermal cutoff switch activated.	Identify and correct the source of the fault. Replace the temperature control unit if required. Allow the appliance sufficient time to cool. If the appliance has been disconnected from the electrical supply, you can then manually reset the thermal cutoff switch by depressing the black button in the center of the switch face.
Very noisy while heating water.	The appliance is scaled.	Descale the appliance.

9. WIRING DIAGRAM

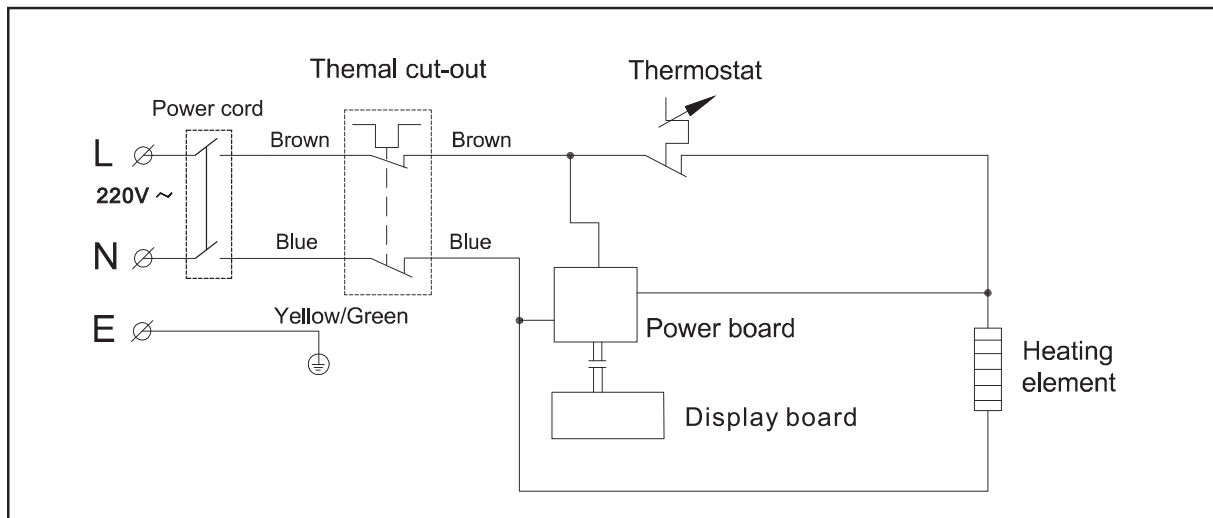

10. WARRANTY

Please visit our webpage for warranty details - falawater.com/warranty-details

Read all instructions before installing or using this appliance.

Fala®

SYDNEY HEAD OFFICE

10 Phiney Place, Ingleburn

NSW 2565 Australia

T: AU 1300 276 642

F: (+61) 1300 735 115

E: fala@bromicgroup.com

FALAWATER.COM